

Example - 600mm wide window - owner builder discretion regarding type and size of window

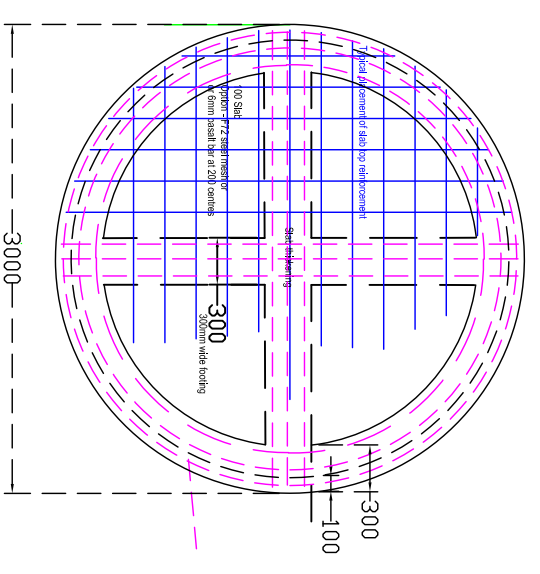

Footing and slab reinforcement
SEE DETAIL - BSLT3.0-2

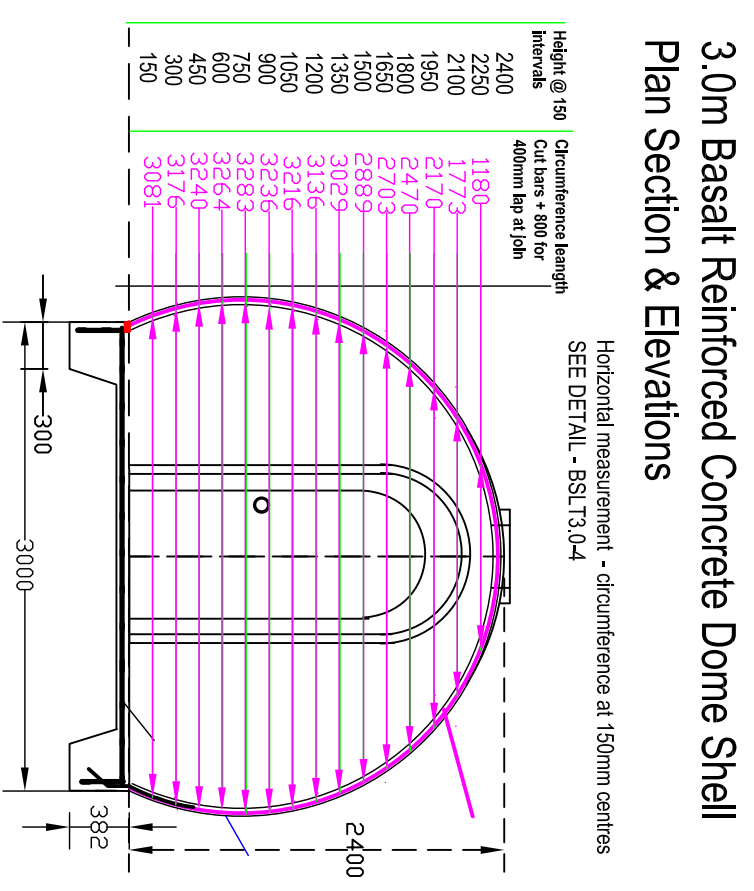
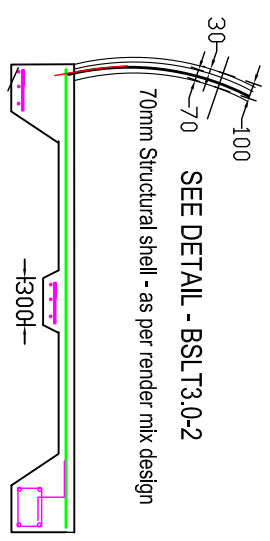

Thickness of shell (100mm (4 inches) comprised of:
a 70mm thick, structural basalt fibre rebar and mesh reinforced concrete shell
a 30mm layer of lightweight thermal concrete (pebble, scoria, air-crete, hemp crete or other) over the top of the structural shell for thermal insulation - (note: the thickness of the thermal layer can be increased to suite conditions or preferences).

Shell structure reinforcing:
6mm basalt fibre rebar placed 150mm vertical x 150mm horizontal.
1-2 layers of 5mm basalt mesh - stretch and fix tightly to the basalt frame.

ELEVATION DOOR

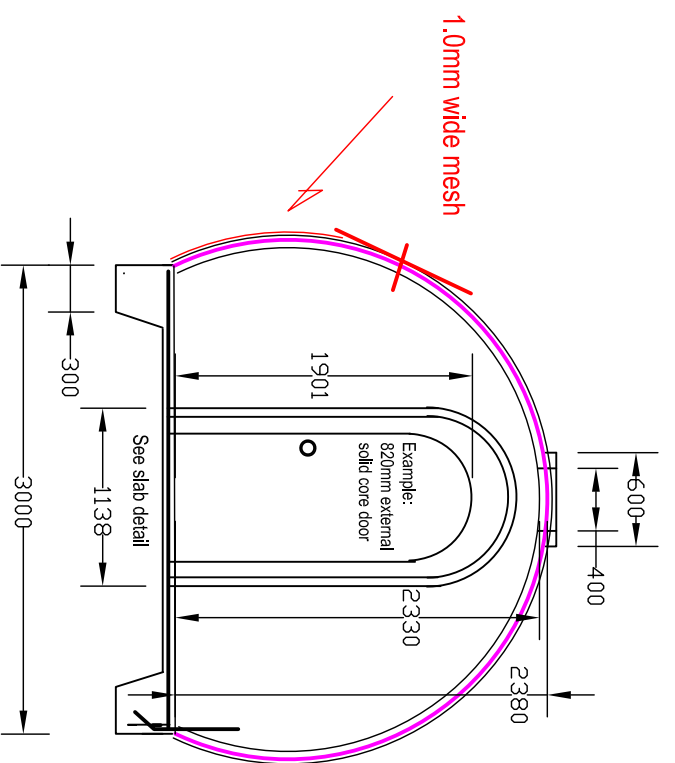

ELEVATION 600 Window

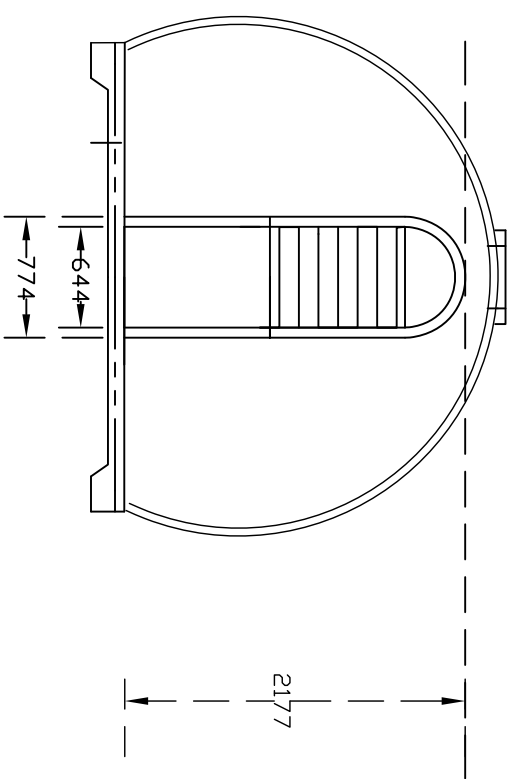

SECTION

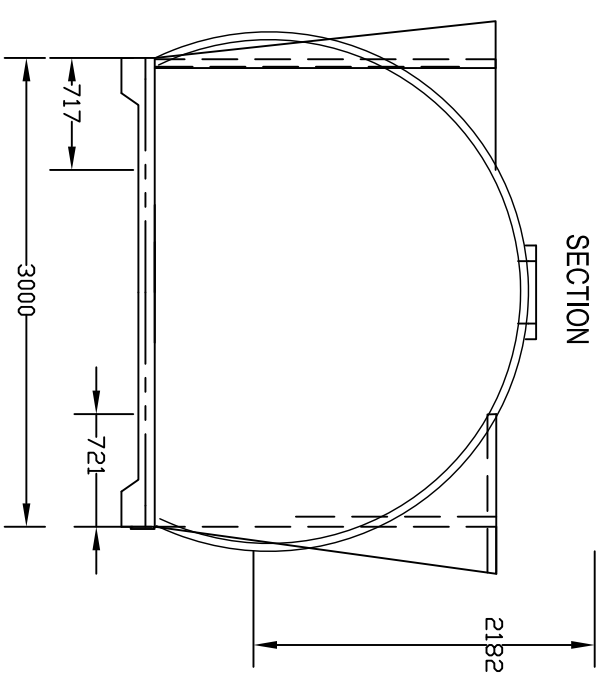

The designs contained within the set of drawings: BSLT3.0-1 to BSLT3.0-10 are to be read simultaneously with the "Basalt Dome Building Manual" and the "On Line Dome Building Workshop".
They are for educational purposes only.
The shells designed to wind speed of 51 mps for a particular site and foundation system designed for that site.
Warranty by Domeshells extends only to an engineered certified design for a particular site and for workmanship that meets Domeshells and industry professional standards.

Domeshells Australia Pty Ltd

ABN:78 108 351 355
P.O.Box 30, Condonig, NSW 2484
Tel:02-6677-0216 Email: contact@domeshells.com.au
http://www.domeshells.com.au
Property of Domeshells Australia Pty, Ltd. and are not to be copied or reproduced without the permission of Domeshells.



References		3.0m Basalt Fibre Reinforced Dome		Sheet - of -
Approve		Plan, Elevations Sections	A3 - Scale 1:50	
Checked			DRG. No.	
Drawn	COB	For Training and Education Purposes	BSLT3.0-1	
Scale:	Name	Signature	Date	REV.

Slab and Footings reinforcement for in ground slab and relocatable slab

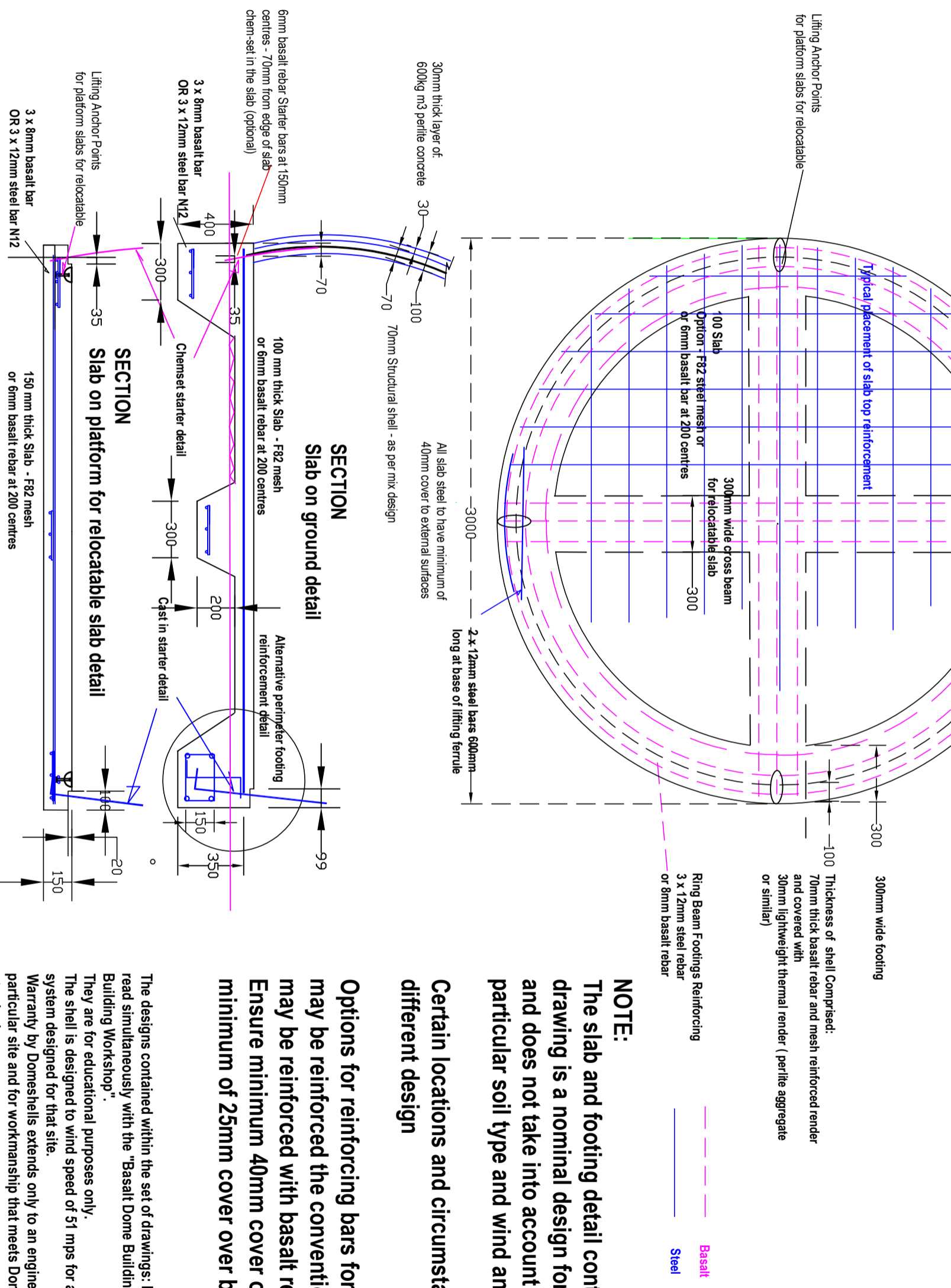

NOTE:
 The slab and footing detail contained in this drawing is a nominal design for certain conditions and does not take into account design for your particular soil type and wind and seismic zone.

Certain locations and circumstances may require a different design

Options for reinforcing bars for footings and slab: may be reinforced the conventional way with steel or may be reinforced with basalt rebar. Ensure minimum 40mm cover over steel and minimum of 25mm cover over basalt

The designs contained within the set of drawings: BSLT3.0-1 to BSLT3.0-10 are to be read simultaneously with the "Basalt Dome Building Manual" and the "On Line Dome Building Workshop". They are for educational purposes only. The shell is designed to wind speed of 51 mps for a particular site and foundation system designed for that site. Warranty by Domeshells extends only to an engineered certified design for a particular site and for workmanship that meets Domeshells and industry professional standards.

REV DATE	BY	DESCRIPTION	GRID REF	CHECKED	APPROVED

Domeshells Australia Pty Ltd	
ABN: 76 108 351 355 P.O Box 30 Candong, NSW 2484 Tel: 02-6677 0216 Email: info@domeshells.com.au Website: https://www.domeshells.com.au	 • d o m e s h e l l s • ©

References	
Approve Checked Drawn Scale:	3.0m Diameter - Basalt Reinforced Concrete Dome Footing & Slab Details and options A3 - Scale 1:25 DRG. No. BSLT3.0-2
Name Signature Date	COB 07-12-202

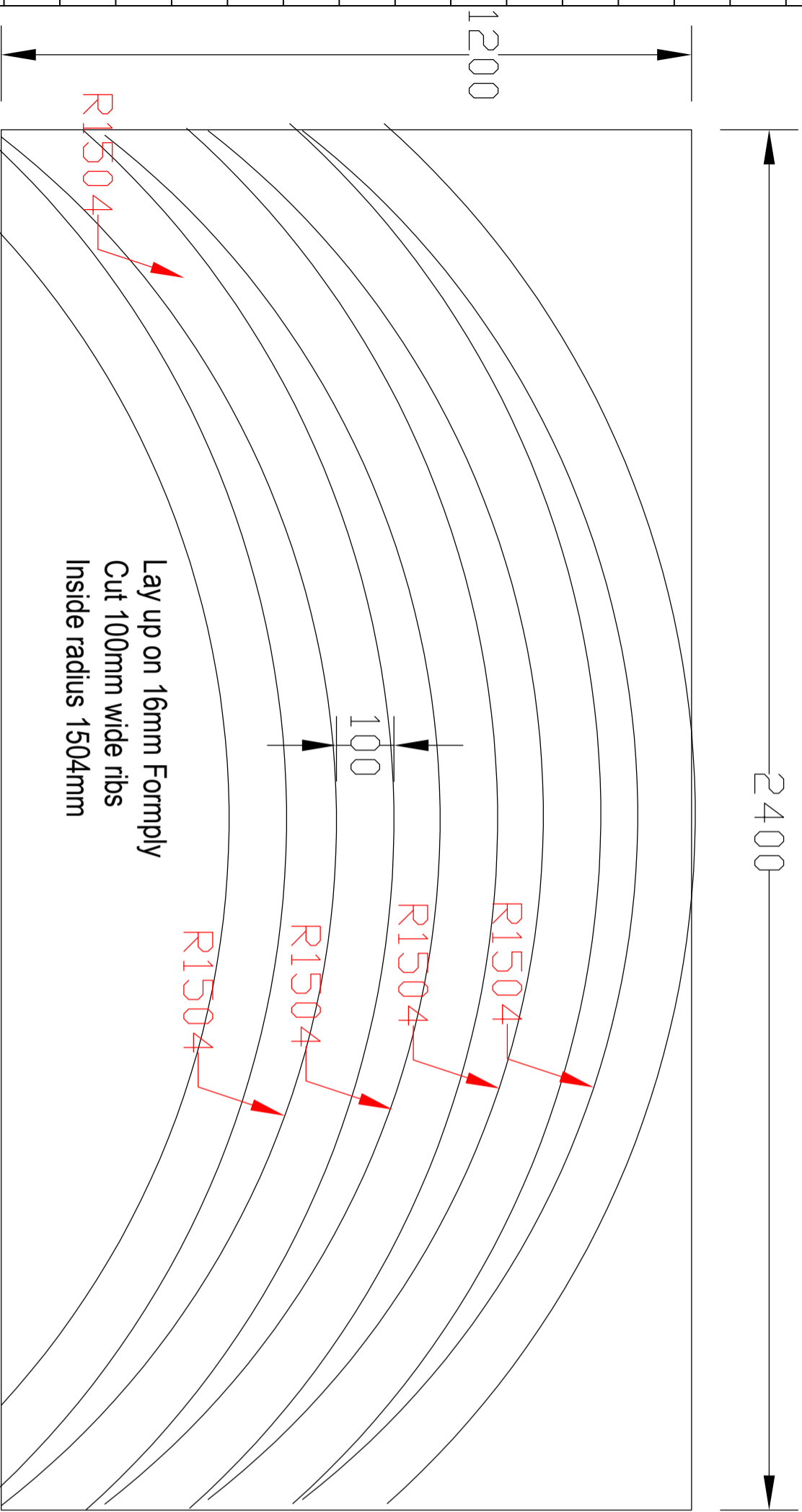

Lay up on 16mm Formply
 Cut 100mm wide ribs
 Inside radius 1504mm

3.0m diameter Dome Typical Slab Former Detail

The finished diameter of the slab is 3.0m
 the radius is 1.5m

Use 4mm ply for the vertical edge
 Use 16mm formply for the outer ribs
 Cut 100mm wide ribs with inside radius of
 1504mm

Typical slab form detail for a slab on ground. NOTE: the depth
 of the ring beam footing could be between 400mm to 600mm

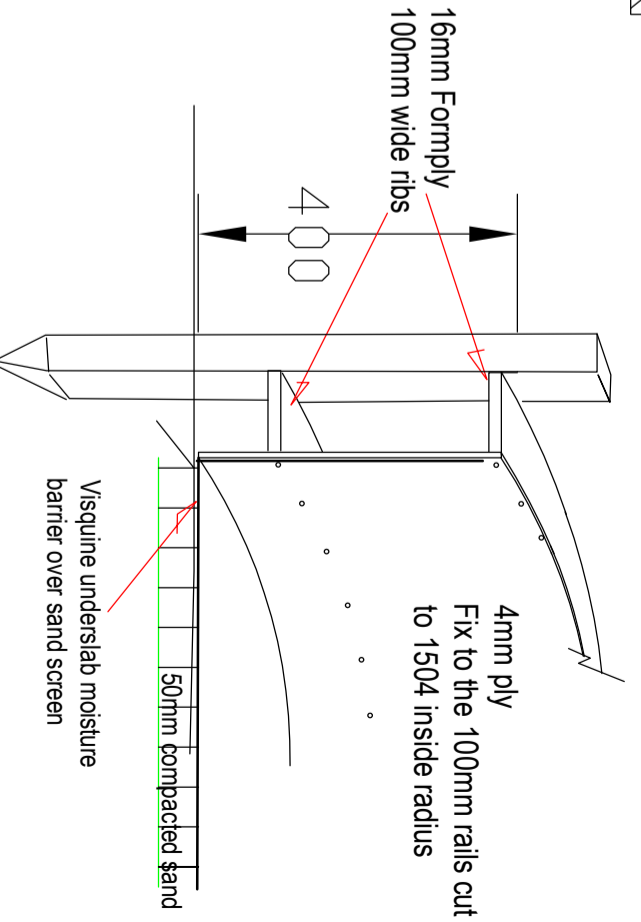

The designs contained within the set of drawings: BSL T3.0-1 to BSL T3.0-10 are to be read simultaneously with the "Basalt Dome Building Manual" and the "On Line Dome Building Workshop". They are for educational purposes only.
 The shell is designed to wind speed of 51 mps for a particular site and foundation system designed for that site.
 Warranty by Domeshells extends only to an engineered certified design for a particular site and for workmanship that meets Domeshells and industry professional standards.

Domeshells Australia Pty Ltd
 P.O.Box 30, Condong, NSW 2484
 Tel:02-6677-0216 Email: contact@domeshells.com.au

This drawing remains the property of DomeShells and is not to be copied, transmitted, nor used without the written permission of DomeShells and is subject to recall at any time.

References		3.0m Dome Slab Former DETAIL		Sheet - of -
Approve				A3 -Scale 1:10
Checked				DWG: BSL T3.0-2a
Drawn	COB			REV/
Date	07/12/2023			

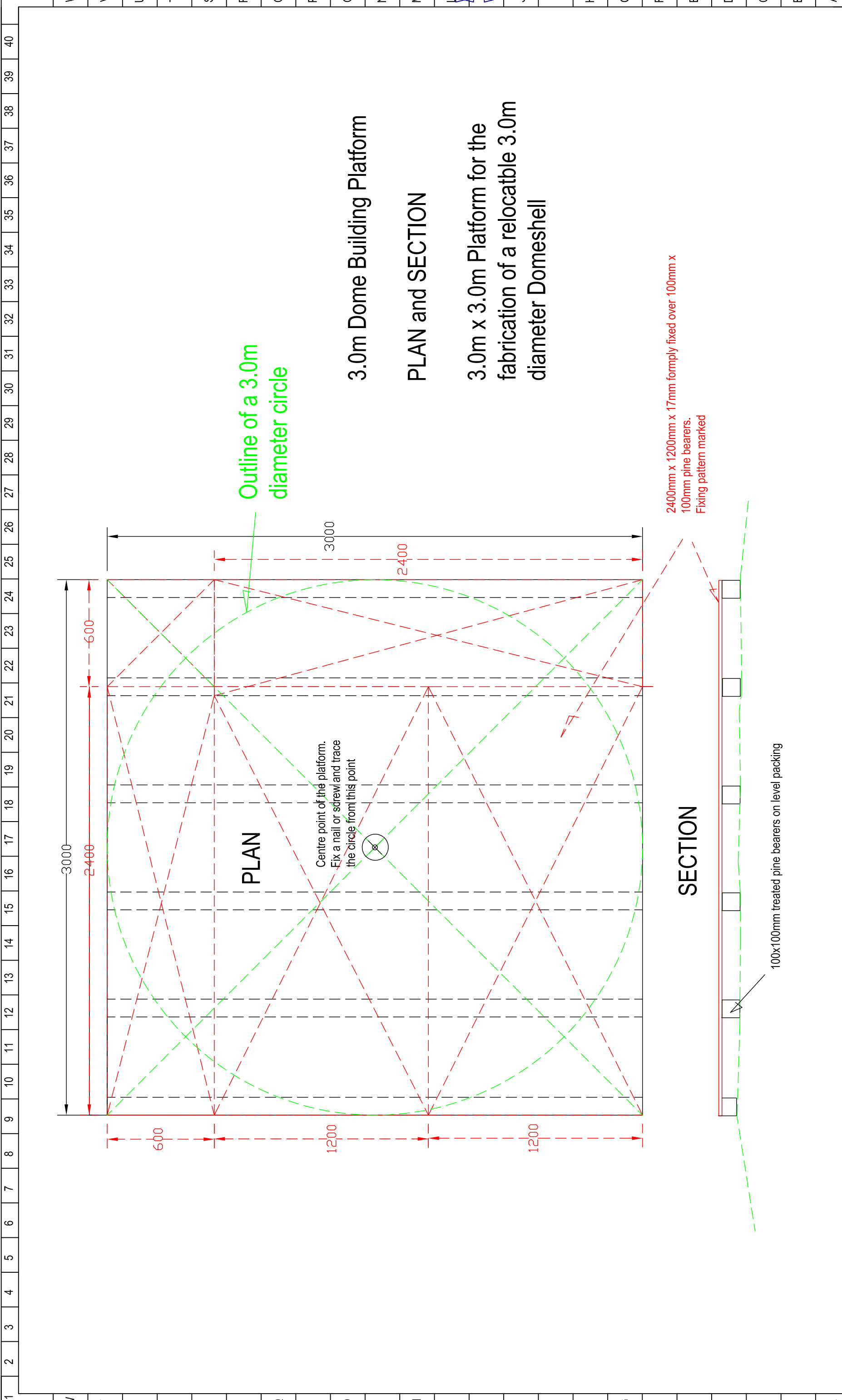

Outline of a 3.0m diameter circle

PLAN

Centre point of the platform.
Fix a nail or screw and trace the circle from this point

SECTION

100x100mm treated pine bearers on level packing

2400mm x 1200mm x 17mm formply fixed over 100mm x 100mm pine bearers.
Fixing pattern marked

3.0m Dome Building Platform
 PLAN and SECTION
 3.0m x 3.0m Platform for the fabrication of a relocatable 3.0m diameter Domeshell

DomesHELLS Australia Pty Ltd ©
 P.O.Box 820, Billinudgel, NSW 2483
 Tel.02-6680-5500 Fax. 02-6680-5511
 Email: contact@domeshells.com.au
 This drawing remains the property of DomesHELLS and is not to be copied, transmitted, nor used without the written permission of DomesHELLS and is subject to recall at any time.

References	
Approve	
Checked	
Drawn	
Scale:	

Sheet - of -	A3 - Scale 1:20
3.0m Dome Building Platform Detail	
BSLT3.0-2b	
REV.	

3.0m - SECTION DETAIL

Horizontal Bar measurement - circumference at 150mm centres

	Circumference plus 800mm for 400mm lap at join	Circumference	Height off slab	Diameter at 150mm centres
Q	5555	4755	2250	1513
P	7061	6261	2100	1992
O	8157	7357	1950	2341
N	8953	8153	1800	2594
M	9606	8806	1650	2802
L	10122	9322	1500	2966
K	10518	9718	1350	3092
J	10801	10001	1200	3182
I	10995	10195	1050	3244
H	11099	10299	900	3277
G	11115	10315	750	3282
F	11043	10243	600	3259
E	10885	10085	450	3209
D	10628	9828	300	3127
C	10247	9447	150	3006

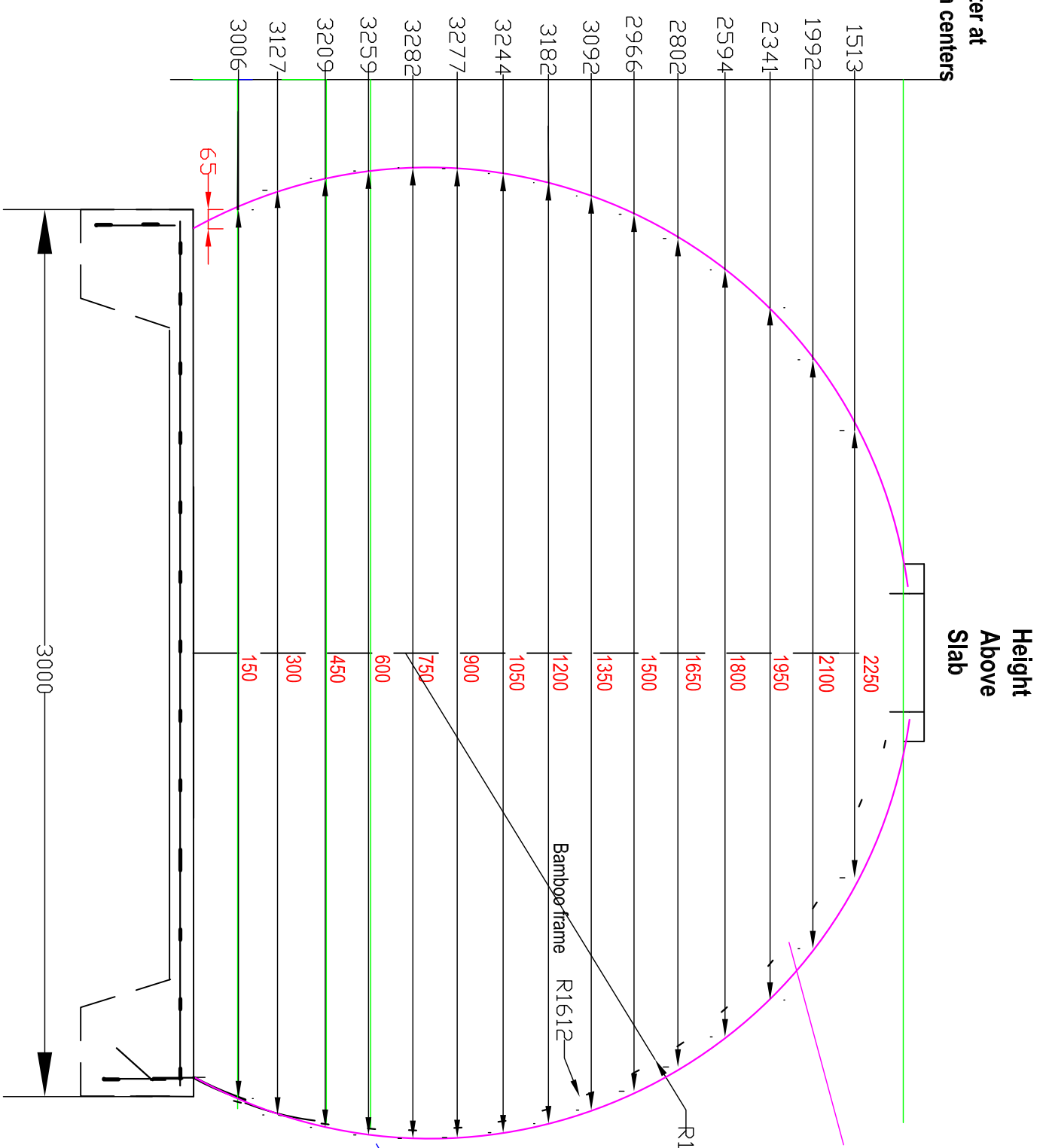

Height Above Slab

Shell structure comprising:
 6mm Basalt Fibre Rebar at 150 vertical x 150 horizontal.
 1 x layer of 5mm basalt fibre mesh (minimum 115gsm)

Render to minimum of 30mm thick cover over the framing externally and internally - minimum overall thickness of 70mm.

Apply 30mm lightweight thermal render (perlite aggregate or similar) over the structural shell.

Render mix design for Structural render
 3 fine washed river sand to 1 general purpose portland cement.
 1 cup Bondcrete

For skim coat render add 2 grams 7mm basalt chopped fibre per 20kg cement
 Apply by render spray machine

Starter bars in slab 600 high at 150mm centres.

Chemset 6mm diameter basalt rebar 150mm centres all way around the slab at the angle the curved dome meets the slab

DomesHells Australia Pty Ltd
 P.O.Box 30, Condong, NSW 2484
 02 6677 0216 contact@domeshells.com.au



References	
Approve	
Checked	
Drawn	CB
Scale:	

3.0m Basalt Dome Horizontal Bar Location & Lengths Sections DETAIL		Sheet - of -	A3 -Scale 1:20
		Dwg:	BSLT3.0-4
		REV.	

This drawing remains the property of DomesHells Australia Pty Ltd and is not to be copied, transmitted, nor used without the written permission of DomesHells and is subject to recall at any time.

07/12/2023

Section
Typical Apex Opening Detail

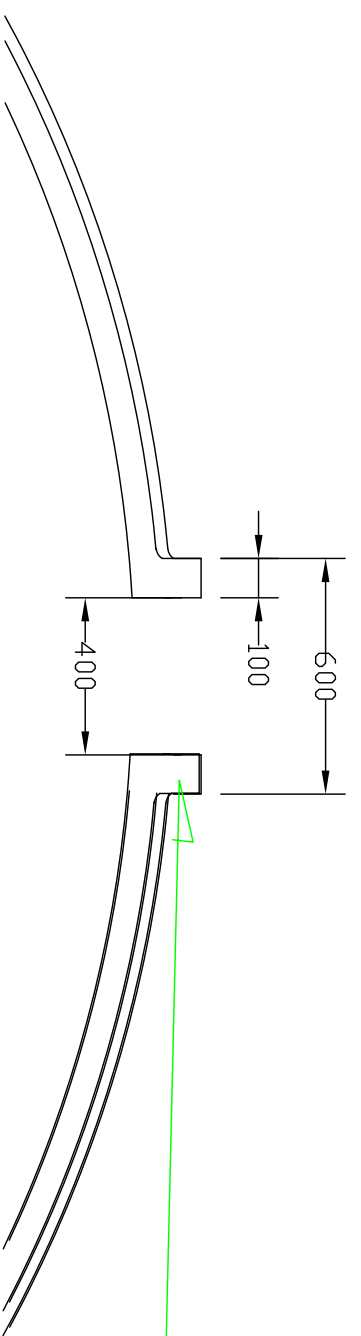

Minimum dimension of the Apex Ring
100mm wide x 70mm high above the structural shell

Proposed minimum thickness of lightweight concrete for thermal insulation (600kg/m³ density perlite lightweight concrete)

Minimum thickness of structural basalt fibre rebar reinforced concrete shell

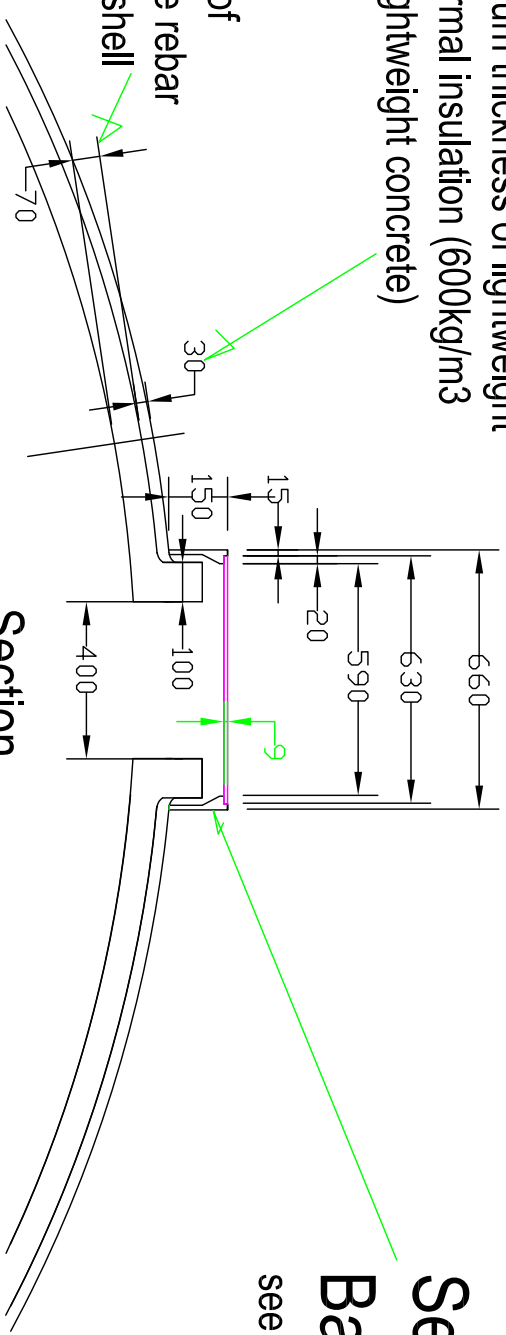

Section
Basalt fibre reinforced concrete skylight
see prefabricated elements

Section
Skylight Mold Parts

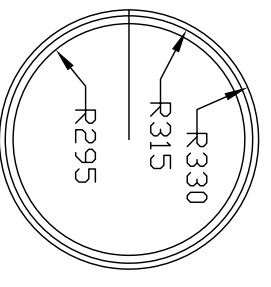
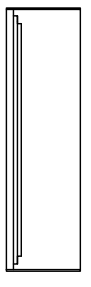

Plan
Skylight mould discs
see: DETAIL BSLT3.0-7

Typical Opening for Apex Skylight NOTE: Dimension of opening size may be determined by the "owner builder". It must however, be in compliance with the structural design required for the local conditions and authorities. Engineering certification is available from DomesHELLS when/if required

DomesHELLS Australia Pty Ltd

P.O.Box 30, Condong, NSW 2484

02 6677 0216 contact@domeshells.com.au

This drawing remains the property of DomesHELLS Australia Pty Ltd and is not to be copied, transmitted, nor used without the written permission of DomesHELLS and is subject to recall at any time.

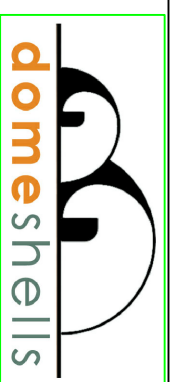

References	
Approve	
Checked	
Drawn	COB
Date:	07/12/2023

400mm Apex Opening
and Skylight Sections
DETAIL

Sheet - of -	
A3 -Scale 1:20	
Dwg:	BSLT3.0-5
REV.	

The Carousel Apex Temporary Ring plate assembly detail - for a 400mm diameter apex skylight hole

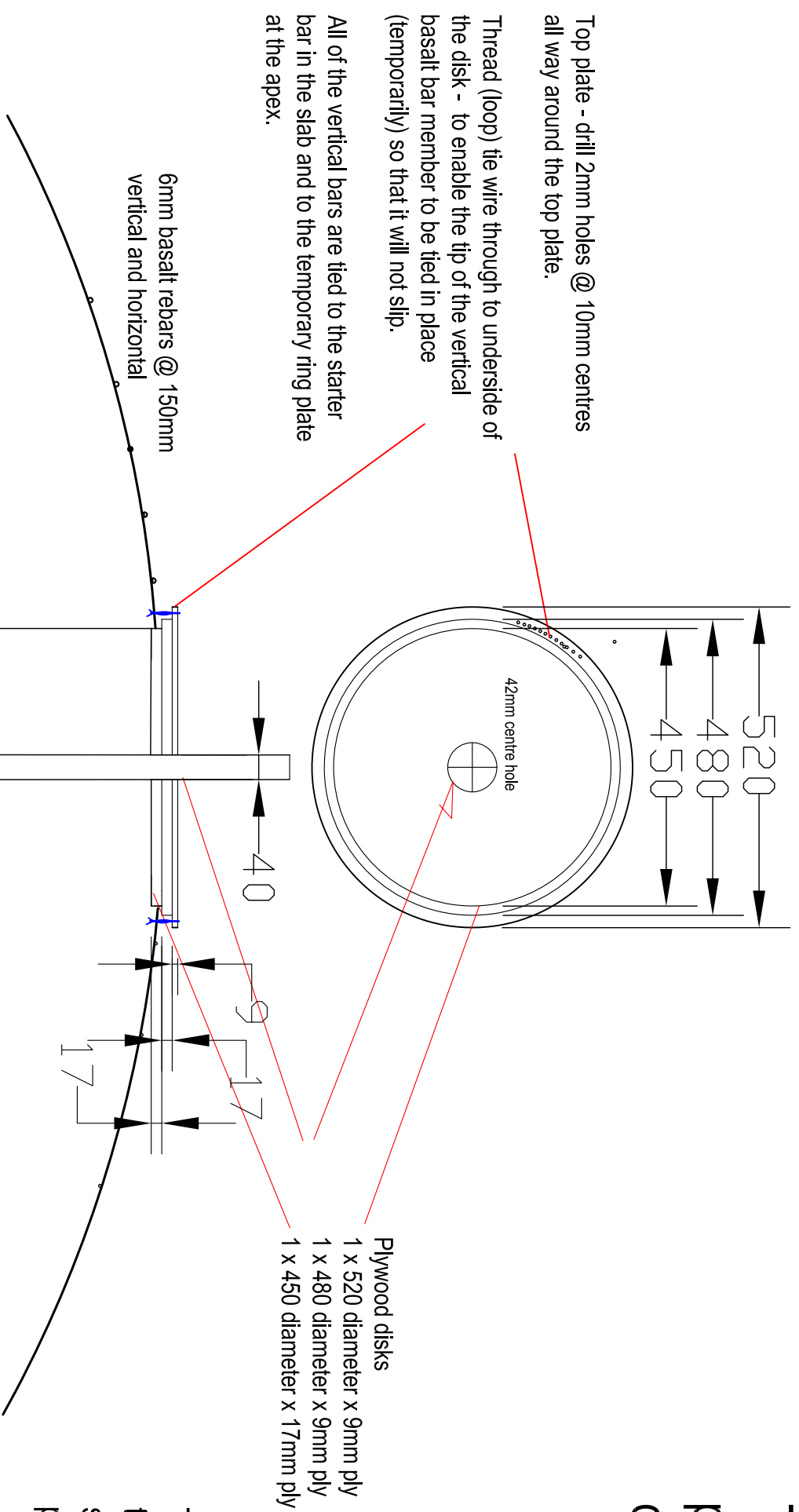

Top plate - drill 2mm holes @ 10mm centres all around the top plate.

Thread (loop) tie wire through to underside of the disk - to enable the tip of the vertical basalt bar member to be tied in place (temporarily) so that it will not slip.

All of the vertical bars are tied to the starter bar in the slab and to the temporary ring plate at the apex.

Plywood disks
 1 x 520 diameter x 9mm ply
 1 x 480 diameter x 9mm ply
 1 x 450 diameter x 17mm ply

The pole and carousel assembly acts to temporarily hold the vertical basalt bars in place until the shell is sufficiently rendered to within 50mm around the perimeter of the carousel.

At this point it can be removed and the pre-cast skylight ring is placed in position and rendered into the shell

200 x 200 x 5mm base plate welded to 40mm CHS.

Use 4x8mm concrete anchor bolts to bolt the plate at the centre of the slab to support top ring assembly that holds vertical basalt bars in place during the rendering process.

A The shell is designed to wind speed of 51 mps for a particular site and foundation system designed for that site.
 Warranty by DomesHELLS extends only to an engineered certified design for a particular site and for workmanship that meets DomesHELLS and industry professional standards.

B The designs contained within the set of drawings: BSL T3.0-1 to BSL T3.0-10 are to be read simultaneously with the "Basalt Dome Building Manual" and the "On Line Dome Building Workshop". They are for educational purposes only.

C The shell is designed to wind speed of 51 mps for a particular site and foundation system designed for that site.
 Warranty by DomesHELLS extends only to an engineered certified design for a particular site and for workmanship that meets DomesHELLS and industry professional standards.

DomesHELLS Australia Pty Ltd
 P.O.Box 30, Condong, NSW 2484
 Tel:02-6677-0216 Email:
 contact@domeshells.com.au



This drawing remains the property of DomesHELLS and is not to be copied, transmitted, nor used without the written permission of DomesHELLS and is subject to recall at any time.

References			Sheet - of -	
Approve			A3	Scale 1:10
Checked			DWG:	BSLT3.0-6
Drawn	COB		REV.	
Date	07/12/2023			

3.0m Dome
 Temporary Pole and Plywood
 Disk Ring Assembly
 The Carousel
 DETAIL

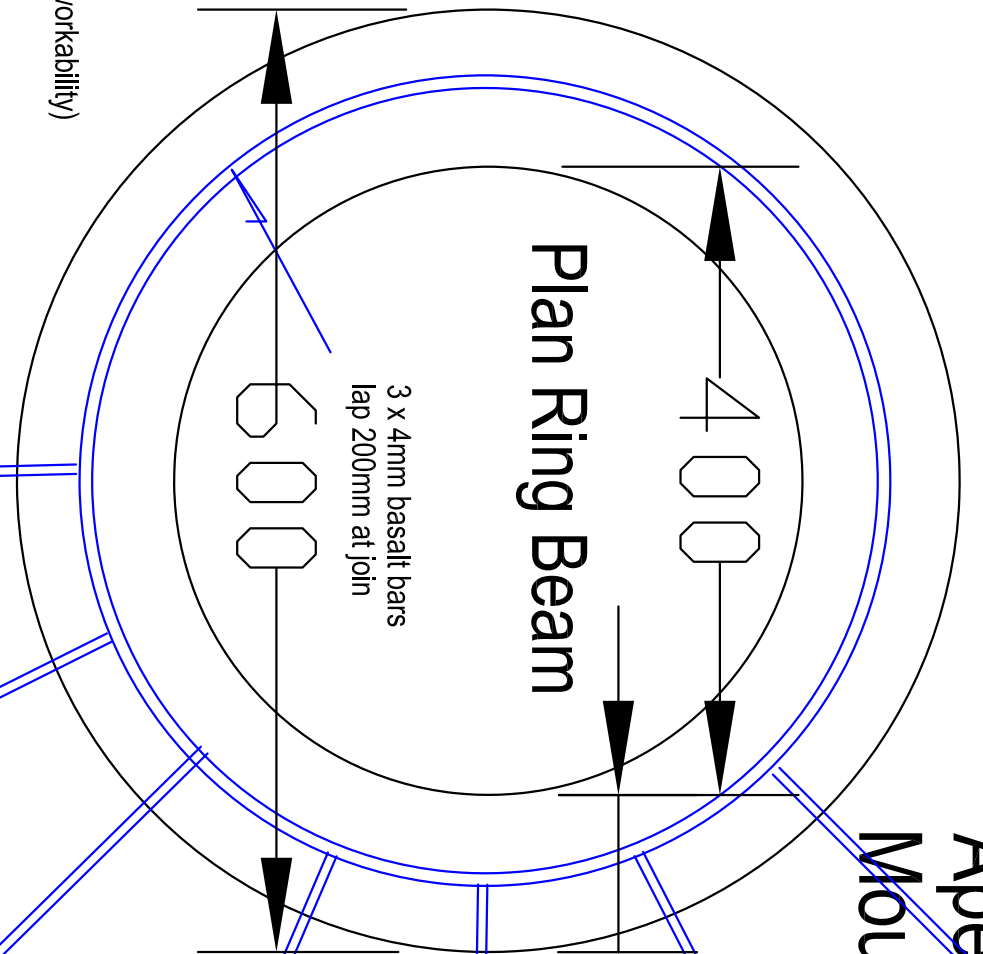
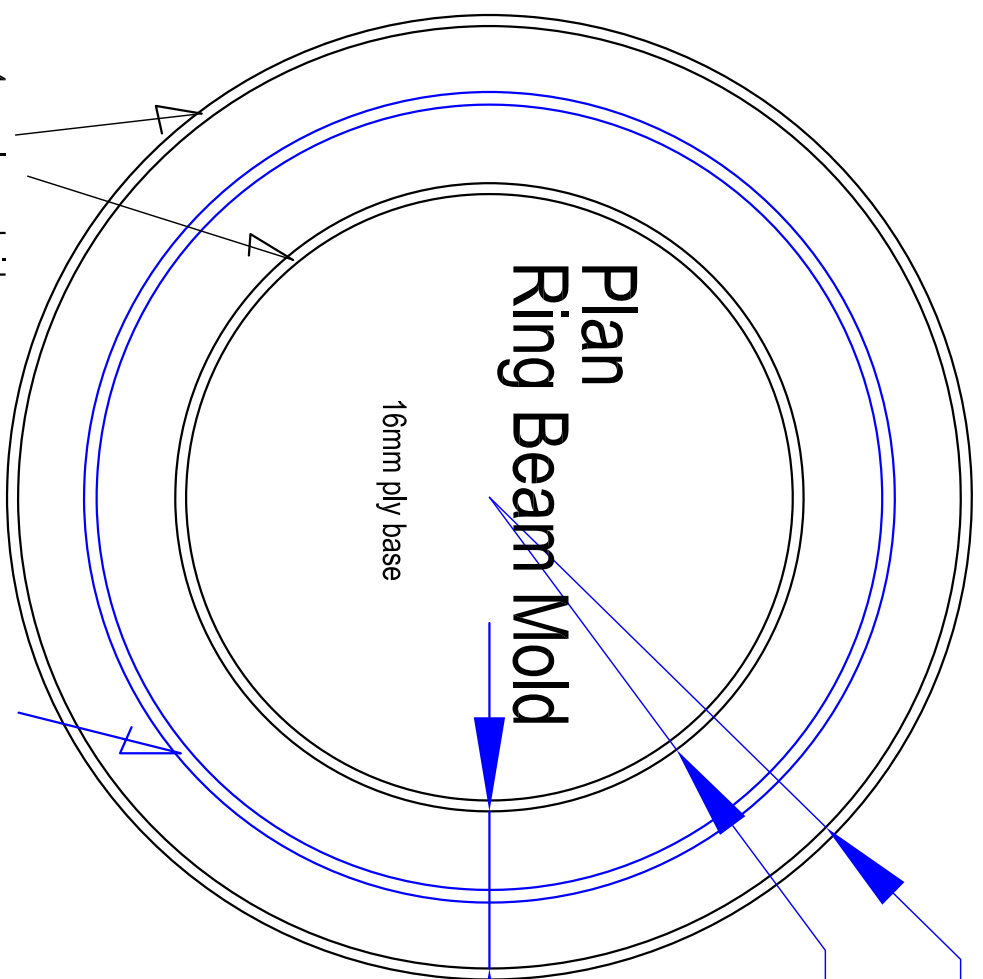

Apex Ring Beam Mould and Fabrication.

Mix Design:
 fine sand to cement - 2:1
 10kg portland cement
 20kg fine sand
 AttaGel - 1 cup (optional for workability)
 7mm basalt fibre - 2 grams
 Bondcrete (or similar polymer) ⁵⁰ with clean water
 Mix to a stiff pliable consistency
 Lay in 1 layer of 5mm basalt fibre mesh

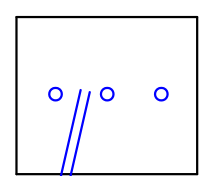
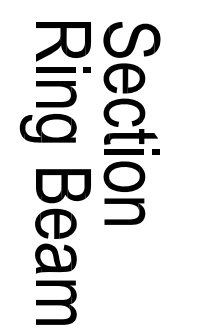
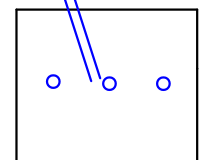
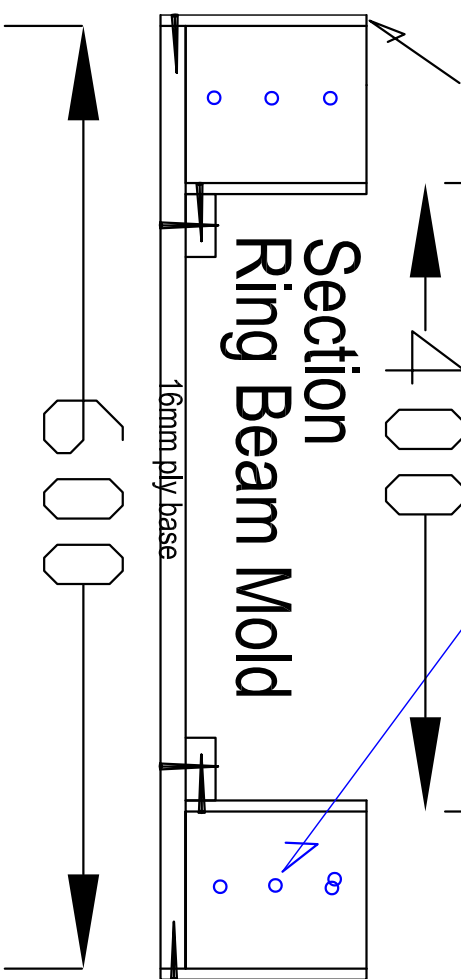

Drill and chenset 6mm bars x 300mm long into side of the ring at 150mm centres

The designs contained within the set of drawings: BSLT3.0-1 to BSLT3.0-10 are to be read simultaneously with the "Basalt Dome Building Manual" and the "On Line Dome Building Workshop". They are for educational purposes only.
 The shell is designed to wind speed of 51 mps for a particular site and foundation system designed for that site.
 Warranty by DomesHELLS extends only to an engineered certified design for a particular site and for workmanship that meets DomesHELLS and industry professional standards.

DomesHELLS Australia Pty Ltd

P.O.Box 30, Condong, NSW 2484
 Tel.02-66770216
 Email: contact@domeshells.com.au

This drawing remains the property of DomesHELLS and is not to be copied, transmitted, nor used without the written permission of DomesHELLS and is subject to recall at any time.

References		Sheet - of -	
Approve		Apex Ring Beam Mold	A3 -Scale 1:5
Checked		& Fabrication	DRG.
Drawn	COB	DETAIL	BSLT3.0-8
Date:	07/12/2023		REV.

Apex Ring Beam to Shell Wall Connection

Not to scale
Illustration only

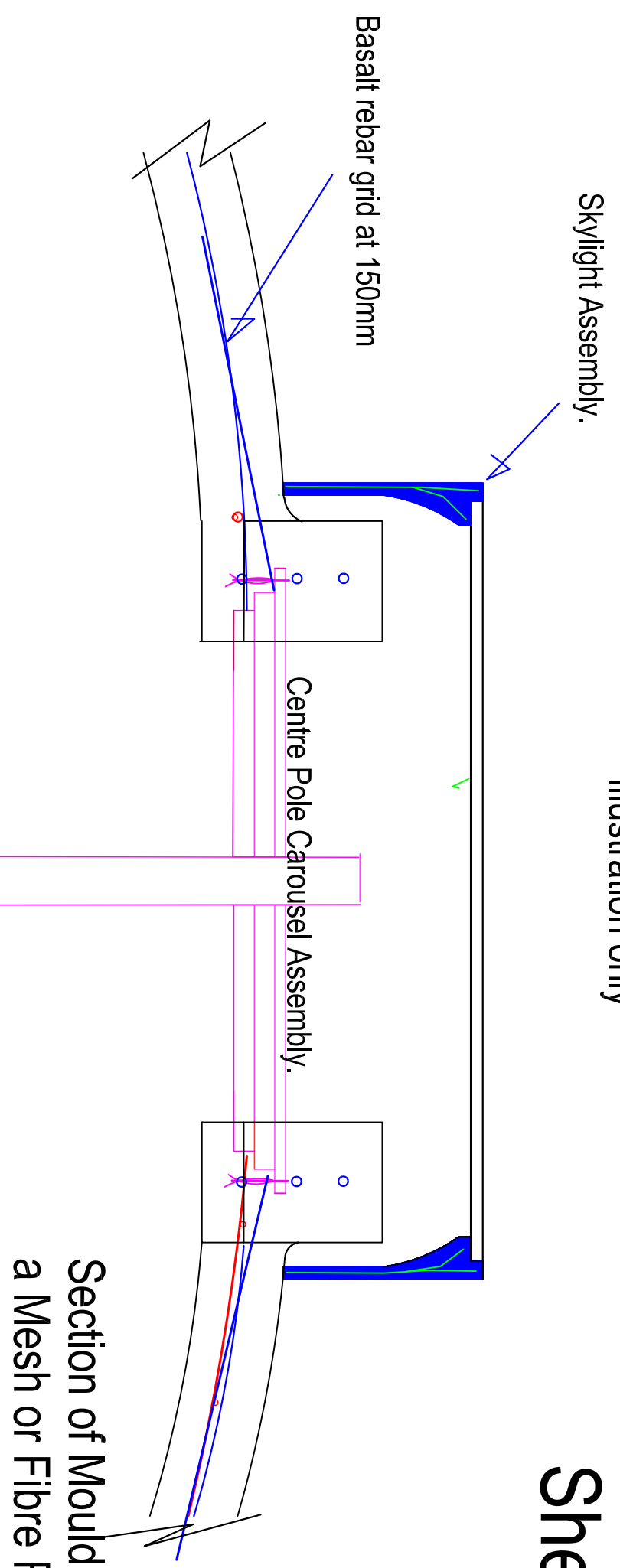

Section of Mould Assembly for the Fabrication of a Mesh or Fibre Reinforced Concrete Skylight.

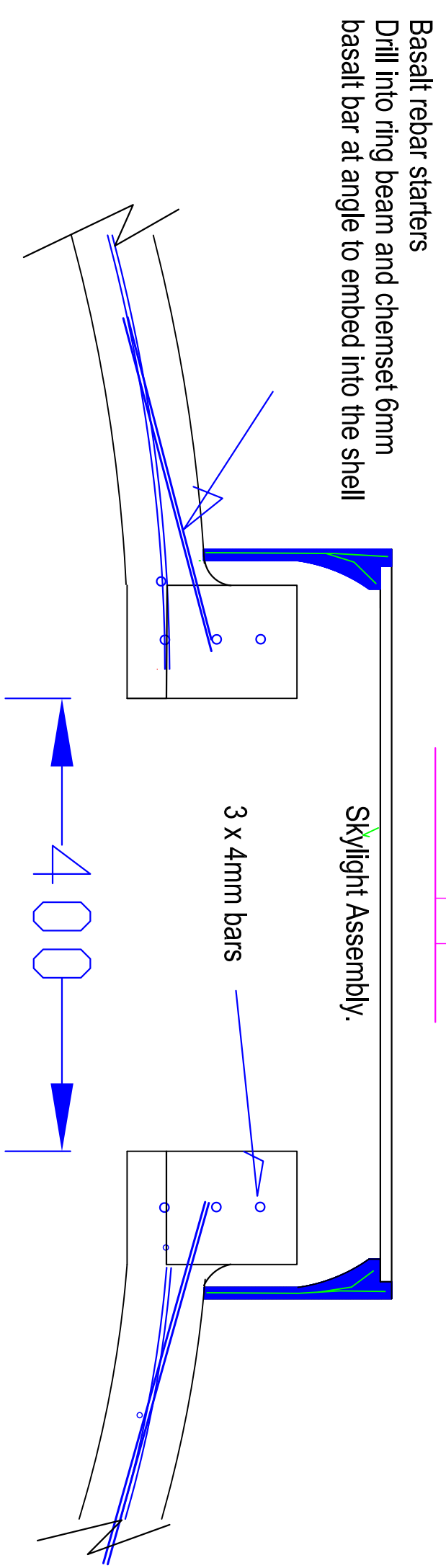

The designs contained within the set of drawings: BSLT3.0-1 to BSLT3.0-10 are to be read simultaneously with the "Basalt Dome Building Manual" and the "On Line Dome Building Workshop". They are for educational purposes only.
The shell is designed to wind speed of 51 mps for a particular site and foundation system designed for that site.
Warranty by Domeshells extends only to an engineered certified design for a particular site and for workmanship that meets Domeshells and industry professional standards.

Domeshells Australia Pty Ltd

P.O.Box 30, Billinudgel, NSW 2484
Tel:02-66770216
Email: contact@domeshells.com.au

This drawing remains the property of Domeshells and is not to be copied, transmitted, nor used without the written permission of Domeshells and is subject to recall at any time.

References		Sheet - of -	A3 -Scale 1:5	
Approve		DRG.	BSLT3.0-9	
Checked		REV.		
Drawn	COB			
Date:	07/12/2023			

Apex Ring Beam to Shell Wall Connection
DETAIL

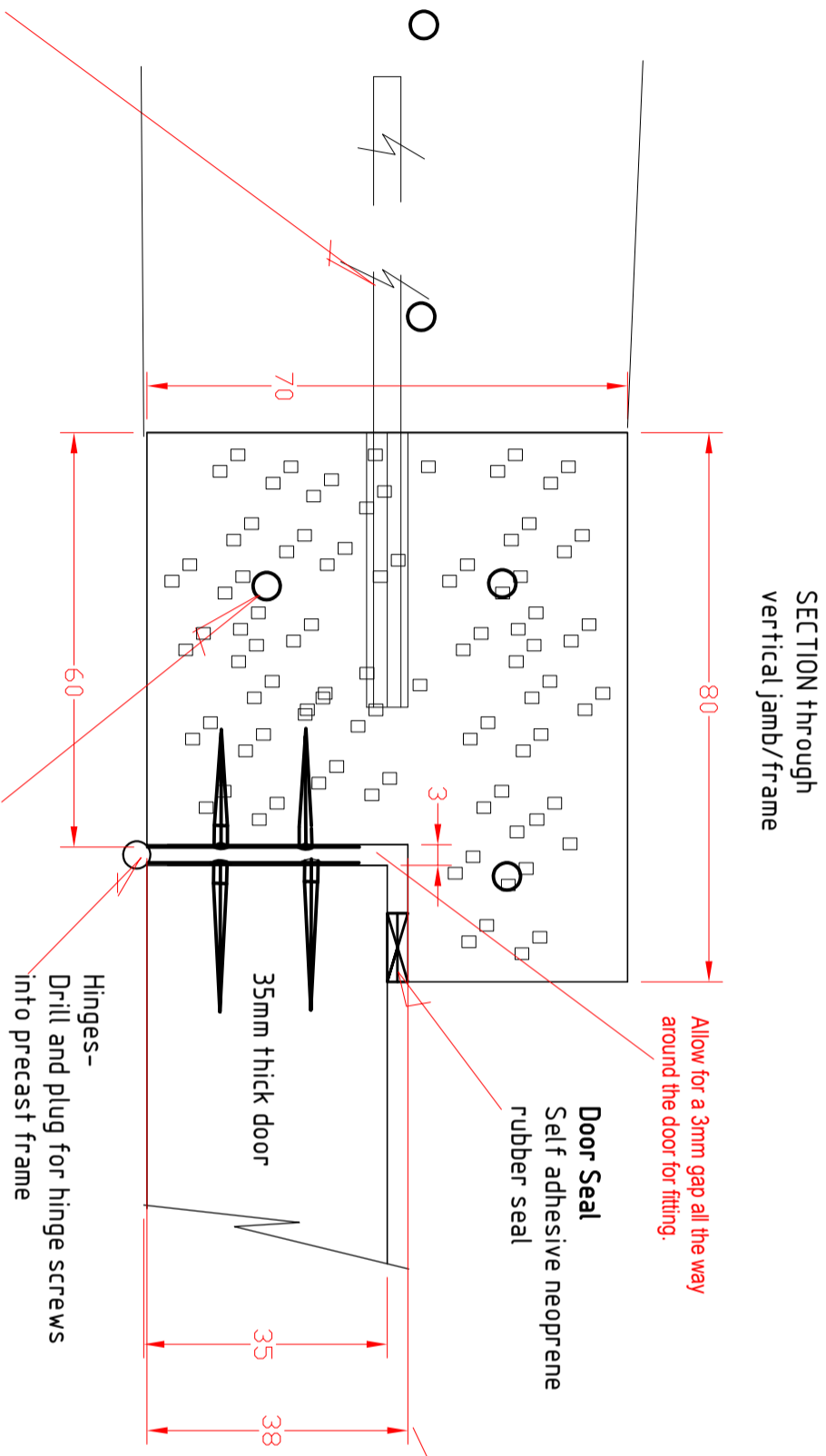

Dowell – 4mm Basalt Bar Starters
x 100mm long.
Drill 5mm hole at 300mm centres
all way around the frame – insert
4mm basalt bar to cast into shell
wall and chemset in place.
Ensure the holes are blown out to
remove ALL dust.

SECTION:
**Precast Basalt Fibre Reinforced
Concrete Door and Window Frames**

REV	DATE	BY	DESCRIPTION	GRID REF	CHECKED	APPROVED

DomeShells Australia
P.O. Box 30, Condong, NSW, 2484
Tel: 02-6677-0216
<https://domeshells.com.au> - contact@domeshells.com.au

d o m e s h e l l s

This drawing remains the property of DomeShells Austral. and is not to be copied, transmitted, nor used without the written permission of DomeShells Austral. and is subject to recall at any time.

References	
Approve	
Checked	
Drawn	Nov 2022
Scale:	
Name	
Signature	
Date	

Section:
PreCast Door and
Window Jamb

Sheet - of -	
A3 - 380x230 - Scale 1:1	
DRG. No.	
BSLT3.0-9.1	
REV	

